

# MTR-60

**FOGEL**  
Refrigerator

Large size undercounter refrigerator with flat worktop.  
Mesa refrigeradora grande, para colocar debajo de mostradores,  
con superficie plana de trabajo.



Top view / Vista superior:  
In [mm] / Pulg. [mm]:

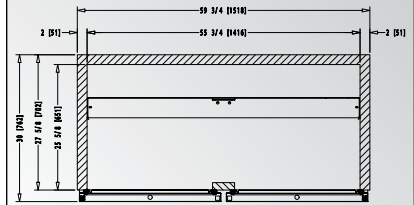

Side view / Vista lateral:  
In [mm] / Pulg. [mm]:

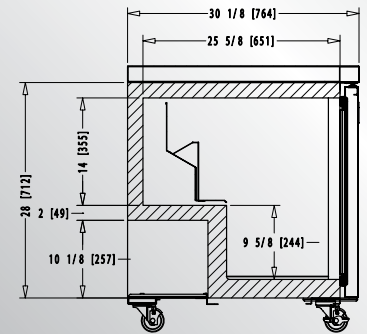

## FEATURES / CARACTERÍSTICAS:

- 430 stainless steel exterior cabinet and top / Gabinete exterior, y sobremostrador, en acero inoxidable 430.
- 430 stainless steel interior bottom and interior rear wall / Fondo de tina y pared interior trasera de acero inoxidable 430.
- Aluminum interior side walls / Paredes interiores laterales de aluminio.
- Electronic control / Control electrónico.
- Electronic fan motors / Motores electrónicos.
- Casters. / Rodos.
- Low maintenance condenser / Condensador de bajo mantenimiento.
- CFC-free polyurethane insulation with cyclopentane as the blowing agent / Aislante de poliuretano, libre de CFCs, con ciclopentano como espumante.

## OPTIONAL / OPCIONAL:

- 304 stainless steel exterior cabinet and top / Gabinete exterior, y sobremostrador, en acero inoxidable 304.
- 304 stainless steel interior bottom and interior rear wall / Fondo de tina y pared interior trasera de acero inoxidable 304.
- 304 or 430 stainless steel interior side walls / Paredes interiores laterales de acero inoxidable 304 o 430.
- Electronic control with energy saving button and Bluetooth Smart® capability. / Control electrónico con botón ahorrador de energía y conectividad Bluetooth Smart®.
- Voltage regulator / Regulador de voltaje.
- Door lock / Cerradura con llave.
- 220V/60Hz/1 or 220V/50Hz/1 voltage / Voltaje 220V/60Hz/1 o 220V/50Hz/1.

DIMENSIONS DIMENSIONES			CAPACITY* CAPACIDAD*		SHIPPING ENVÍO	TECHNICAL INFORMATION INFORMACIÓN TÉCNICA					
in / pulg mm											
Height Alto	Width Frente	Depth Fondo	Cubic ft / Lt. Pies3 / lts.	Shelves Parrillas	40' / 45' - container Contenedor de 40' / 45'	Temperature Temperatura	HP	Amps Amperaje	Refrigerant Refrigerante	Voltage Voltaje	Doors Puertas
34 9/16 878	59 3/4 1,518	30 1/8 764	17.5 / 495	2	28 / 32	34°F - 39°F +1°C - +4°C	1/6	1.7	R 290	115V/60Hz/1	2



FOGEL DE CENTROAMÉRICA  
3ra. Ave. 8-92 Zona 3 Lotificación El Rosario, Mixco, Guatemala. 01057 | PBX: +502-2356-3000 | Fax: +502-2438-0960  
E-mail: foca@fogel-group.com | www.fogel-group.com

All features and information is subject to change. Images with illustrative purposes only. / Todas las especificaciones e información está sujeta a cambios.  
Todas las imágenes son con fines ilustrativos únicamente.